

1 2 3 4 5 6 7 8

更改 REV	变更内容 MODIFICATION	日期 DATE	制图 DRAW	审核 APPROVE
A	版面发行	2012/10/29	JDL	Oscar

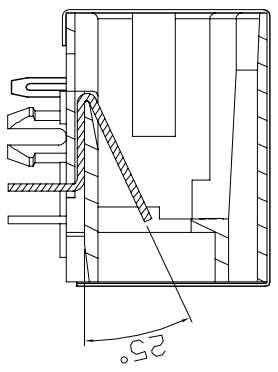
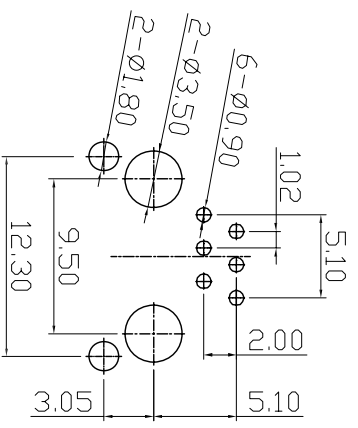
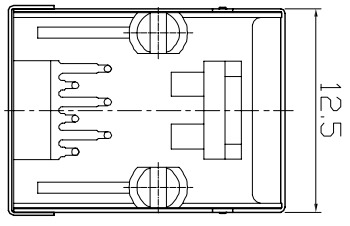
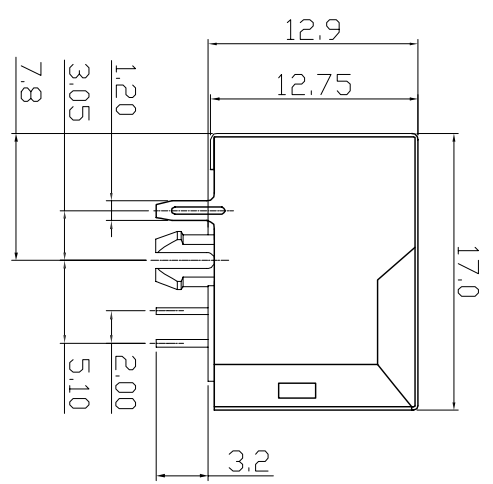
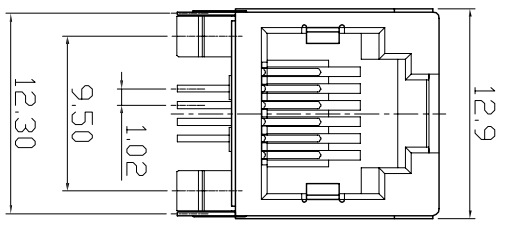

- NOTES:
- MATERIAL:
- 1.HOUSING MATERIAL :GLASS FILLED POLYESTER(U94V-0).
 - 2.CONTACT MATERIAL :PHOSPHOR BRONZE T=0.35mm.
 - 3.PLATING :GOLD PLATING OVER NICKEL.
 - 4.SHIELD COPPER ALLOY 0.20mm THICKNESS PLATING Ni.
- ELECTRICAL:
- 1.VOLTAGE RATING :125 VAC RMS.
 - 2.CURRENT RATING :1.5 AMP.
 - 3.CONTACT RESISTANCE :50 MILLIOHMS MAX.
 - 4.INSULATION RESISTANCE :500 MEGOHMS MIN @ 500V DC.
 - 5.DIELECTRIC WITHSTANDING RESISTANCE :1000V AC RMS 50HZ, 1MIN.
- MECHANICAL:
- 1.DURABILITY :750 CYCLES MIN.
 - 2.PCB RETENTION PRE-SOLDER :1 LB MIN.
- ENVIRONMENTAL:
- 1.STORAGE :-40°C TO +85°C.
 - 2.OPERATION : 0°C TO 70°C.
- MATES WITH MODULAR PLUG CONFORMING TO FCC PART 68,SUBPART F.

PART NUMBER: 58C-S1166C-XX

- 1-GOLD PLATING "U"
- 1-FU" 2-2U" 3-3U" 4-6U"
- PLASTIC MATERIAL:COLOR:Black/Yellow/Gray
- 1-PCB: 20X2F Black
- 2-PA46 Black

HTTP://WWW.RJ45JACK.COM		YOU LONG CONNECT THE WORLD	
DIMENSION IN mm [Inch]		YOU LONG ELECTRONICS LIMITED	
TOLERANCE UNLESS OTHERWISE SPECIFIED		图号 DWG NO. YL58C-S1166C	
.X±0.20	X*±1"	标题 TITLE 58C 1X1 6P6C PCB JACK WITH SHIELDED SIDE ENTRY,TAB-UP,ROUND PIN	
.XXX±0.15	.X*±0.5"	比例 SCALE 1:1	
.XXX±0.075		图幅 SIZE A3	
检验 APPROVE	检查 CHECK	审核 REV 1	
Oscar		A	

PC Board Layout



1 2 3 4 5 6 7 8

If you have any questions,Don't hesitate to email sales@rj45jack.com,please!