

1 2 3 4 5 6 7 8

更改 REV	变更内容 MODIFICATION	日期 DATE	制图 DRAW	审核 APPROVE
A	版面发行	2012/10/29	JDL	Oscar

NOTES:

ELECTRICAL:

- VOLTAGE RATING : 125 VAC RMS.
- CURRENT RATING : 1.5 AMP.
- CONTACT RESISTANCE : 50 MILLIOHMS MAX.
- INSULATION RESISTANCE: 500 MEGOHMS MIN @ 500 VDC.
- DIELECTRIC STRENGTH : 500 VAC RMS 50Hz, 1MIN.

MECHANICAL:

- HOUSING MATERIAL : NYLON(PA46)+30%G.F UL94V-0.
- CONTACT MATERIAL : PHOSPHOR BRONZE T=0.35mm (C55210)
: GOLD-PLATED IN THE CONTACT AREA
- PLATING
- SHIELD,COPPER ALLOY(OR STEEL ALLOY) 0.20mm THICKNESS
- OPERATING LIFE : 750 CYCLES MIN.
- PCB RETENTION PRE-SOLDER : 1 LB MIN.
- PCB RETENTION POST-SOLDER: 10 LBS MIN.

ENVIRONMENTAL:

- STORAGE : -40°C TO +85°C.
 - OPERATION: 0°C TO +70°C.
 - IR REFLOW PEAK SOLDERING TEMPERATURE:255°C~265°C 5~10 SECONDS.
 - ROHS COMPLIANT
 - FCC PART 68, SUBPART F.
- MATES WITH MODULAR PLUG CONFORMING TO

PART NUMBER: DIPE-S1188L0-H2XX

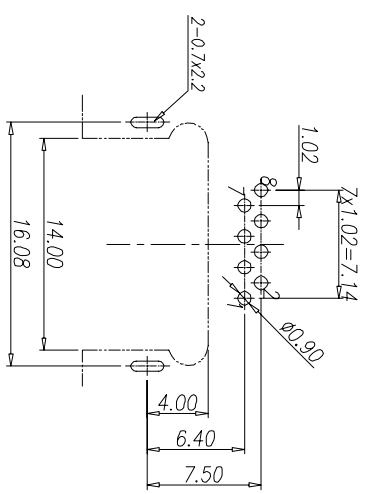
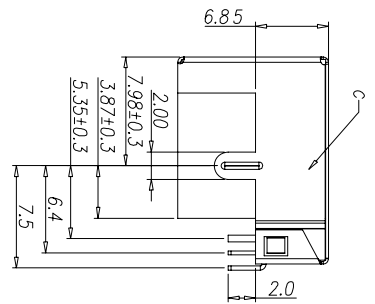
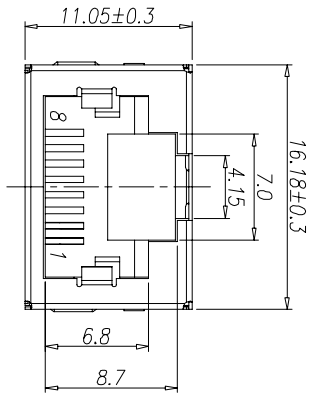
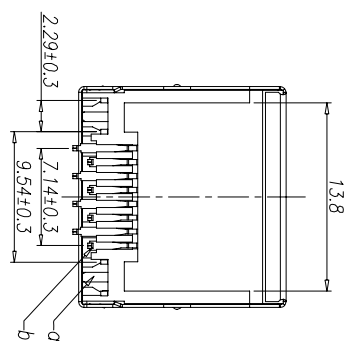
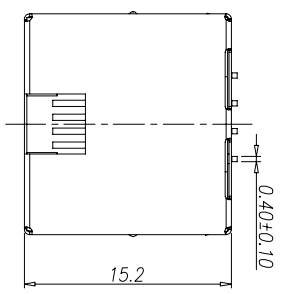

Recommend PCB Layout
(Jack Top View)
Tolerance: ±0.05mm

: Inspection Item		: Cp/Cpk and SPC Control Item	
HTTP://WWW.RJ45JACK.COM			
DIMENSION IN mm [Inch]		YOU LONG CONNECT THE WORLD	
TOLERANCE UNLESS OTHERWISE SPECIFIED		YOU LONG ELECTRONICS LIMITED	
.X±0.20	X.*±1"	图号 FILE NO.	YLDIPE-S1108L0-H2
.XX±0.15	.X.*±0.5"	图号 DWG NO.	YLDIPE-S1108L0-H2
.XXX±0.075		标题 TITLE	DIP TYPE, 1X1 8P8C Embedded PCB JACK WITH SHIELDED H=6.85MM, SIDE ENTRY,TAB-UP,FLAT PIN
批准 APPROVE	检查 CHECK	制图 DRAW	Oscar
		比例 SCALE	1:1
		图框 SIZE	A3
		审核 REV	1 / 1

- GOLD PLATING U"
 - 1-Fu 2-2u" 3-3u" 4-6u"
 - 5-15u" 6-30u"
- PLASTIC MATERIAL&COLOR:Black/Yellow/Grey
- 1-PEIT*20XGF Black
- 2-PA46 Black
- 3-CP Black



1 2 3 4 5 6 7 8

If you have any questions,Don't hesitate to email sales@rj45jack.com,please!