

1 2 3 4 5 6 7 8

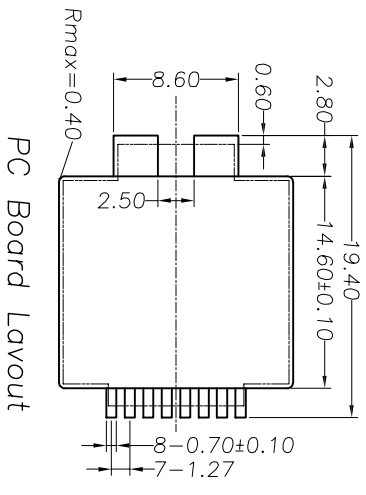
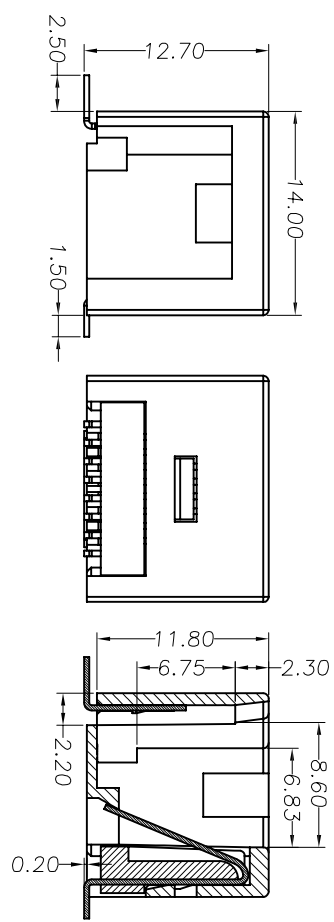
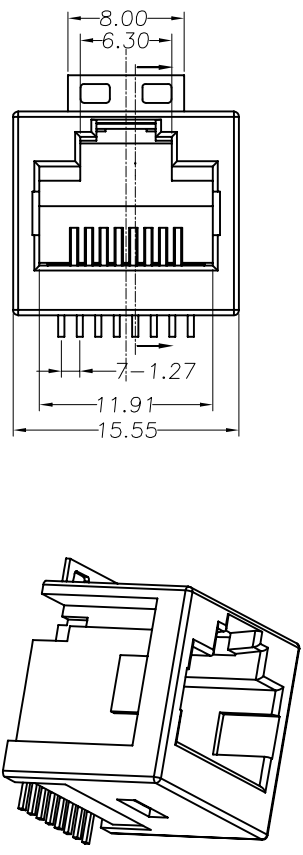

NOTES:

MATERIAL:

- 1.HOUSING MATERIAL :GLASS FILLED POLYESTER(UL94V-0).
  - 2.CONTACT MATERIAL :PHOSPHOR BRONZE T=0.35mm (C5191).
  - 3.PLATING :GOLD PLATING OVER NICKEL.
- ELECTRICAL:
- 1.VOLTAGE RATING :125 VAC RMS.
  - 2.CURRENT RATING :1.5 AMP.
  - 3.CONTACT RESISTANCE :50 MILLIOHMS MAX.

4.INSULATION RESISTANCE :500 MEGOHMS MIN @ 500V DC.

MECHANICAL: :1000V AC RMS 50HZ. 1MIN.

1.DURRABILITY :750 CYCLES MIN.

2.PCB RETENTION PRE-SOLDER

ENVIRONMENTAL: :1 LB MIN.

1.STORAGE : -40°C TO +85°C.

2. OPERATION : 0°C TO 70°C.

MATES WITH MODULAR PLUG CONFORMING TO FCC PART 68,SUBPART F.

PART NUMBER: SMT-N1188-H33X

- GOLD PLATING :u"
  - 1-HU" 2-2U" 3-3U" 4-6U"
  - 5-15U" 6-30U"
- PLASTIC MATERIAL&COLOR:Black/Yellow/Gray
  - 1-PBT+20%GF Black
  - 2-PA66 Black
  - 3-LCP Black

更改 REV	变更内容 MODIFICATION	日期 DATE	制图 DRAW	批准 APPROVE
A	版面发行	2012/10/29	JDL	Oscar

HTTP://WWW.RJ45JACK.COM YOU LONG ELECTRONICS LIMITED		YOU LONG CONNECT THE WORLD	
DIMENSION IN mm [Inch]		TOLERANCE UNLESS OTHERWISE SPECIFIED	
.X±0.20 X*±1*		.X±0.15 X*±0.5*	
.XXX±0.075		.XXX±0.075	
:Inspection Item		:Cp/Cpk and SPC Control Item	
FILE NO.		DWG NO. YLSMT-N1188-H3	
TITLE SMT 1X1 8P8C PCB JACK V/D SHIELDED H=12.7MM ,TOP ENTRY,FLAT PIN		制图 Oscar	
比例 SCALE 1:1		图框 SIZE A3	
审核 1		批准 1	

1 2 3 4 5 6 7 8