

REV	变更内容 MODIFICATION	日期 DATE	制图 DRAW	审核 APPROVE
A	版面发行	2012/10/29	JDL	Oscar

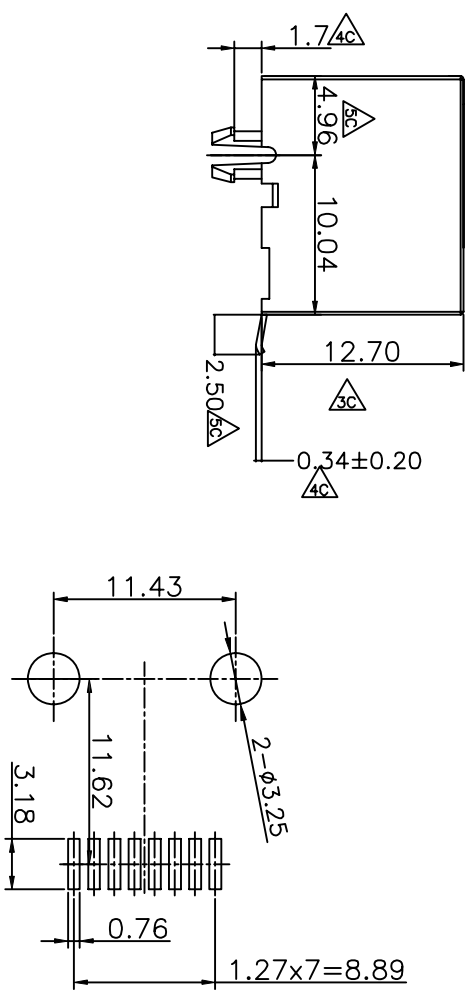
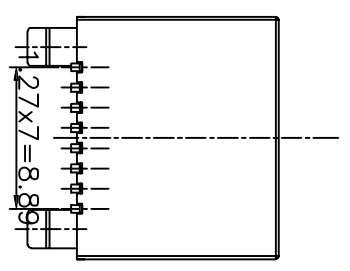
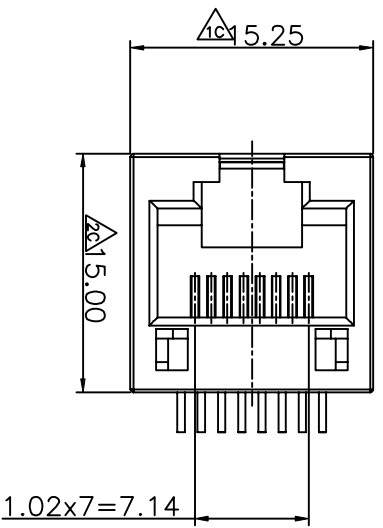

NOTES:

MATERIALS:
PLASTIC HOUSING: HIGH TEMP THERMOPLASTIC
FLAMMABILITY RATING UL 94V-0.
CONTACTS: PHOSPHOR BRONZE
PLATING: GOLD PLATING OVER NICKEL IN CONTACT.
TIN PLATING OVER NICKEL IN SOLDER AREA.
SOLDER PAD: BRASS WITH TIN PLATING OVER NICKEL.

Electrical:
 1.Voltage Rating:125 Vac Rms.
 2.Current Rating:1.5 Amp.
 3.Contact Resistance:40 Milliohms Max. @500 Vdc.
 4.Insulation Resistance:1000 Megohms Min @500 Vdc.
 5.Dielectric Strength:1000 Vac Rms 60HZ, 1Min.
Mechanical:
 1.Operating:750 Cycles Min.
Environmental:
 1.Storage:-40°C To +85°C.
 2.Operation:-20°C To +75°C.
 3.IR Reflow Soldering Temperature:255°C To 265°C(5~10 Seconds).
 Mates With Modular Plug Conforming To FCC Part 68, Subpart F.

PART NUMBER: SMT-N1188D-H334

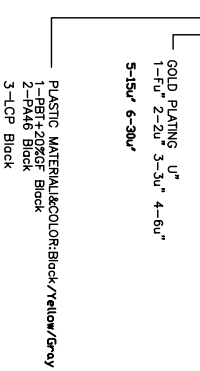

PCB LAYOUT/TOP VIEW

HTTP://WWW.RJ45JACK.COM		YOU LONG ELECTRONICS LIMITED	
:Inspection Item		YOU LONG CONNECT THE WORLD	
:Cp/Cpk and SPC Control Item		YOU LONG ELECTRONICS LIMITED	
DIMENSION IN mm [Inch]		YOU LONG ELECTRONICS LIMITED	
TOLERANCE UNLESS OTHERWISE SPECIFIED		YOU LONG ELECTRONICS LIMITED	
X ± 0.20	X ± 1"	YOU LONG ELECTRONICS LIMITED	
.XXX ± 0.15	.X ± 0.5"	YOU LONG ELECTRONICS LIMITED	
.XXX ± 0.075		YOU LONG ELECTRONICS LIMITED	
批准	检查	YOU LONG ELECTRONICS LIMITED	
批准	检查	YOU LONG ELECTRONICS LIMITED	
文件号	图号	比例	审核
FILE NO.	DWG NO.	SCALE	REV
	YLSMT-N1188D-H3	1:1	1
标题		制图	审核
SMT 1X1 8P8C PCB JACK V/D SHIELDED		OSCAR	A
H=12.7MM ,TOP ENTRY/FLAT PIN		比例	审核
		SCALE	REV
		1:1	1

