

REV	更改内容	日期	制图	审核
A	版面发行	2012/10/29	JDL	Oscar

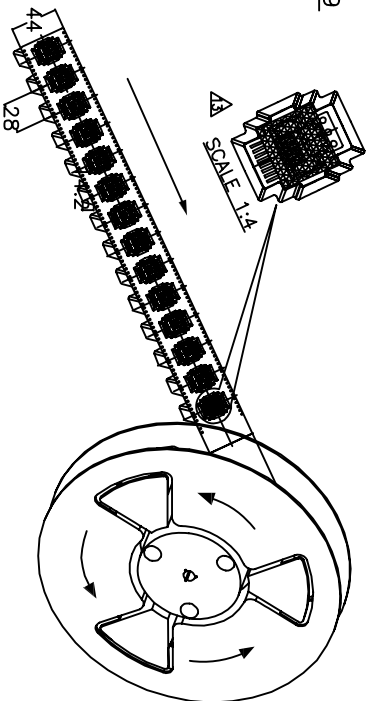
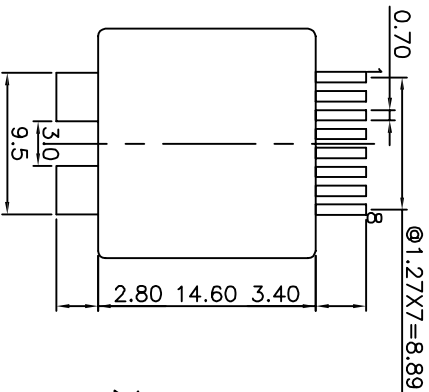
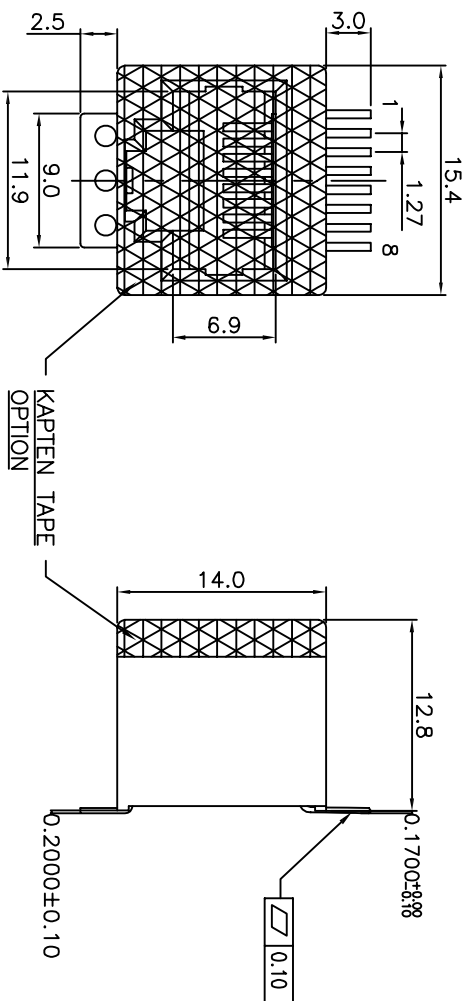

PCB LAYOUT (COMPONENT SIDE VIEW)

RT NUMBER: SMT-LN1188-H324

- NOTES:**
- ELECTRICAL:**
- VOLTAGE RATING : 125 VAC RMS.
 - CURRENT RATING : 1.5 AMP.
 - CONTACT RESISTANCE : 30 MILLIOHMS MAX.
 - INSULATION RESISTANCE: 1000 MEGOHMS MIN @ 500 VDC.
 - DIELECTRIC STRENGTH : 1000 VAC RMS 60Hz, 1MIN.
- MECHANICAL:**
- HOUSING MATERIAL : NYLON+GF30% UL94V-0 /COLOR:BLACK
 - CONTACT MATERIAL : PHOSPHOR BRONZE $t=0.35mm$.
 - SHIELD MATERIAL : 0.35mm THICKNESS BRASS; PLATING NICKEL.
 - PLATING : GOLD PLATING OVER NICKEL.
 - OPERATING LIFE : 750 CYCLES MIN.
 - PCB RETENTION POST-SOLDER: 10 LBS MIN.
- ENVIRONMENTAL:**
- STORAGE : -40°C TO +85°C.
 - OPERATION : -40°C TO +85°C.
 - IR REFLOW PEAK SOLDERING TEMPERATURE : 255°C TO 265°C (5~10 SECONDS).
 - RoHS COMPLIANT
- MATES WITH MODULAR PLUG CONFORMING TO FCC PART 68, SUBPART F.

- GOLD PLATING "U"
1-FU 2-2U 3-3U 4-6U
5-15U 6-30U
- PLASTIC MATERIAL&COLOR:Black/Yellow/Grey
1--PBT+20%GF Black
2--PAET +30%GF Black
3--CP Black

HTTP://WWW.RJ45JACK.COM		YOU LONG CONNECT THE WORLD	
:Inspection Item		YOU LONG ELECTRONICS LIMITED	
:Cp/Cpk and SPC Control Item		DWG NO. YLSMT-LN1188-H3	
DIMENSION IN mm [Inch]		FILE NO.	
TOLERANCE UNLESS OTHERWISE SPECIFIED		图号	
.X±0.20	X*±1*	SMT 1X1 8P8C PCB JACK WITH UNSHIELDED H=12.7MM ,TOP ENTRY,FLAT PIN	
.XXX±0.15	.X*±0.5*	标题	
.XXX±0.075		SMT 1X1 8P8C PCB JACK WITH UNSHIELDED H=12.7MM ,TOP ENTRY,FLAT PIN	
批准	检查	制图	审核
批准	检查	Oscar	1
SCALE 1:1		图例	1
SCALE A3		图例	1
SCALE A		图例	1



If you have any questions,Don't hesitate to email sales@rj45jack.com,please!