

REV	变更内容 MODIFICATION	日期 DATE	制图 DRAW	批准 APPROVE
A	版面发行	2012/10/29	JDL	Oscar

NOTES:

- MATERIAL:
- HOUSING MATERIAL :GLASS FILLED POLYESTER(U94V-0).
 - CONTACT MATERIAL :PHOSPHOR BRONZE $\phi 0.46\text{mm}$ (C5100).
 - PLATING :GOLD PLATING OVER NICKEL.
 - SHIELD,COPPER ALLOY 0.20mm THICKNESS PLATING NI.
- ELECTRICAL:
- VOLTAGE RATING :125 VAC RMS.
 - CURRENT RATING :1.5 AMP.
 - CONTACT RESISTANCE :50 MILLIOHMS MAX.
 - INSULATION RESISTANCE :500 MEGOHMS MIN @ 500V DC.
 - DIELECTRIC WITHSTANDING RESISTANCE :1000V AC RMS 50Hz. 1MIN.
- MECHANICAL:
- DURABILITY :750 CYCLES MIN.
 - PCB RETENTION PRE-SOLDER :1 LB MIN.
- ENVIRONMENTAL:
- STORAGE : -40°C TO +85°C.
 - OPERATION : 0°C TO 70°C.
- MATES WITH MODULAR PLUG CONFORMING TO FCC PART 68,SUBPART F.

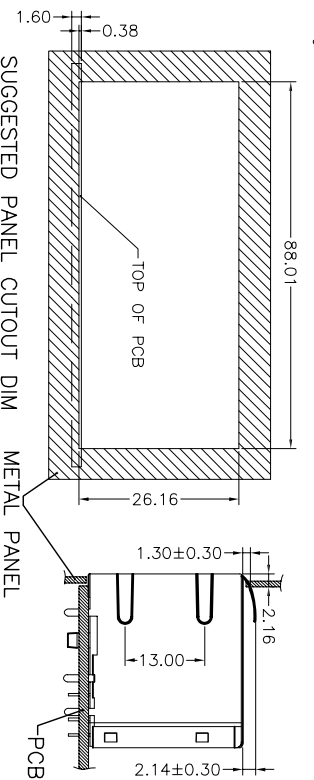
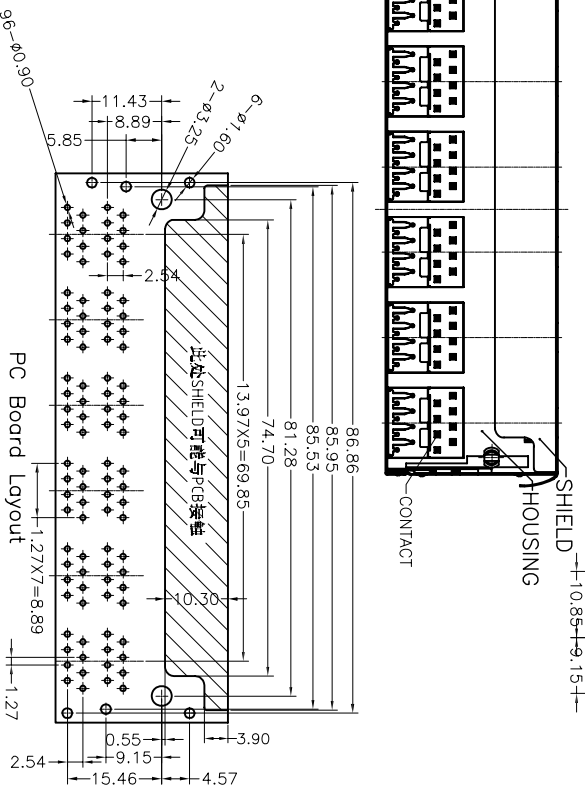
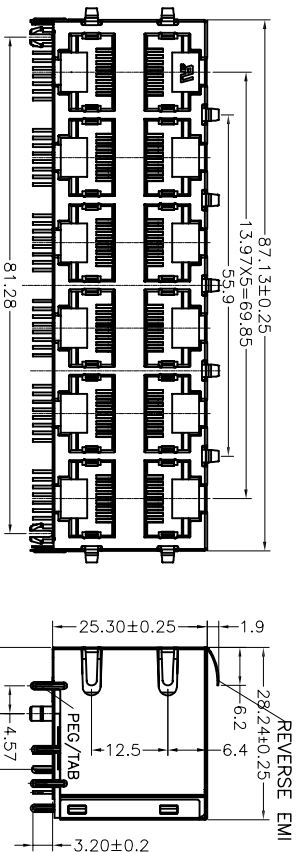

PART NUMBER: 59A-S2688A-E2XX

GOLD PLATING "u"
1-FU" 2-20" 3-30" 4-60"
PLASTIC MATERIAL:COLOR:Black/Yellow/Gray
1-PCB 2-DIMAG Block
1-FX16 Block

HTTP://WWW.RJ45JACK.COM		YOU LONG CONNECT THE WORLD	
: Cp/Cpk and SPC Control Item		YOU LONG ELECTRONICS LIMITED	
DIMENSION IN mm [Inch]		文件号 FILE NO.	
TOLERANCE UNLESS OTHERWISE SPECIFIED		图号 DWG NO. YL59A-S2688A-E2	
.X±0.20	X.*±1"	59A 2X6 8P9C PCB JACKS SHIELDED WITH BACKWARD EMI FINGERS, SIDE ENTRY, ROUND PIN	
.XX±0.15	.X.*±0.5"	标题 TITLE	
.XXX±0.075		OSCAR	
批准 APPROVE	检查 CHECK	制图 DRAW	审核 SCALE
		比例 SCALE	图幅 SIZE
		1:1	A3
		1	1

If you have any questions, Don't hesitate to email sales@rj45jack.com, please!