

更改 REV	变更内容 MODIFICATION	日期 DATE	制图 DRAW	审核 APPROVE
A	版面发行	2012/10/29	JDL	Oscar

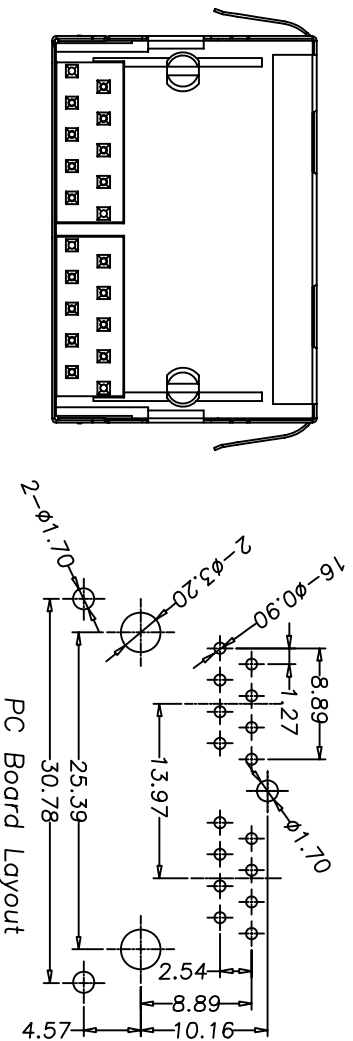

- NOTES:**
- ELECTRICAL:**
- VOLTAGE RATING : 125 VAC RMS.
  - CURRENT RATING : 1.5 AMP.
  - CONTACT RESISTANCE : 50 MILLIOHMS MAX.
  - INSULATION RESISTANCE: 500 MEGOHMS MIN @ 500 VDC.
  - DIELECTRIC STRENGTH : 1000 VAC RMS 50HZ, 1MIN.
- MECHANICAL:**
- HOUSING MATERIAL : NYLON+30% G.F UL94V-0.
  - CONTACT MATERIAL : PHOSPHOR BRONZE 0.46mm.
  - PLATING : GOLD PLATING OVER NICKEL.
  - SHIELD: COPPER ALLOY(OR STEEL ALLOY) 0.20mm THICKNESS PLATING NI.
  - LED:OPTION
  - OPERATING LIFE : 750 CYCLES MIN.
  - PCB RETENTION PRE-SOLDER : 1 LB MIN.
  - PCB RETENTION POST-SOLDER: 10 LBS MIN.
- ENVIRONMENTAL:**
- STORAGE : -40°C TO +85°C.
  - OPERATION: 0°C TO +70°C.
  - WAVE SOLDERING TEMPERATURE: 255~265° (5~10SECONDS).
  - ROHS COMPLIANT
- MATES WITH MODULAR PLUG CONFORMING TO FCC PART 68, SUBPART F.
- PART NUMBER: 59A-S1208A-E2XX

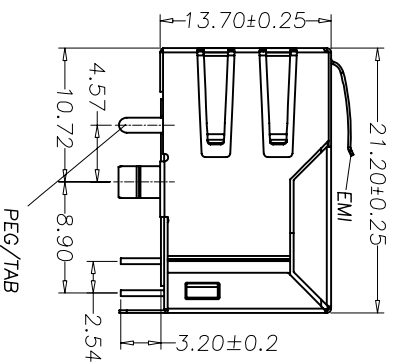
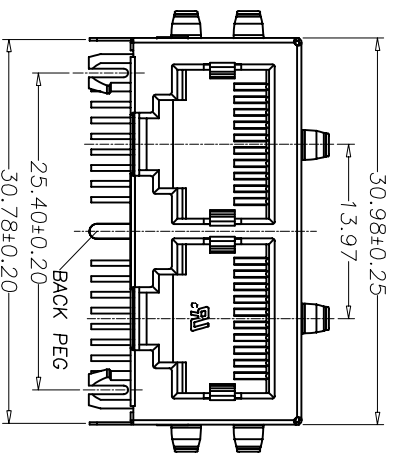
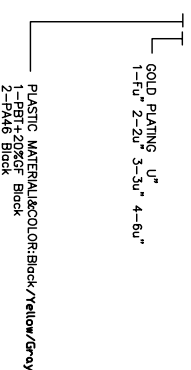

HTTP://WWW.RJ45JACK.COM		YOU LONG CONNECT THE WORLD	
:Cp/Cpk and SPC Control Item		YOU LONG ELECTRONICS LIMITED	
DIMENSION IN mm [Inch]		图号 FILE NO.	图号 DWG NO.
TOLERANCE UNLESS OTHERWISE SPECIFIED		YLS9A-S1208A-E2	
.X±0.20	X.±1"	59A 1X2 8P8C PCB JACK&SHIELDED WITH EMI FINGER	
.XX±0.15	.X.±0.5"	SIDE ENTRY,ROUND PIN	
.XXX±0.075		比例 SCALE	审核 REV
批准 APPROVE	检查 CHECK	制图 DRAW	审核 REV
:Inspection Item		Oscar	1
:Cp/Cpk and SPC Control Item		1:1	A



If you have any questions,Don't hesitate to email sales@rj45jack.com,please!