

更改 REV	变更内容 MODIFICATION	日期 DATE	制图 DRAW	审核 APPROVE
A	版面发行	2012/10/29	JDL	Oscar

**NOTES:**

**ELECTRICAL:**

- VOLTAGE RATING : 125 VAC RMS.
- CURRENT RATING : 1.5 AMP.
- CONTACT RESISTANCE : 50 MILLIOHMS MAX.
- INSULATION RESISTANCE: 500 MEGOHMS MIN @ 500 VDC.
- DIELECTRIC STRENGTH : 1000 VAC RMS 50HZ, 1MIN.

**MECHANICAL:**

- HOUSING MATERIAL : NYLON+30% G.F UL94V-0.
- CONTACT MATERIAL : PHOSPHOR BRONZE  $\phi$ 0.46mm.
- PLATING : GOLD PLATING OVER NICKEL.
- SHIELD: COPPER ALLOY(OR STEEL ALLOY) 0.20mm THICKNESS PLATING NI.
- LED:OPTION
- OPERATING LIFE : 750 CYCLES MIN.
- PCB RETENTION PRE-SOLDER : 1 LB MIN.
- PCB RETENTION POST-SOLDER: 10 LBS MIN.

**ENVIRONMENTAL:**

- STORAGE : -40°C TO +85°C.
- OPERATION: 0°C TO +70°C.
- WAVE SOLDERING TEMPERATURE: 255~265° (5~10SECONDS).
- ROHS COMPLIANT

MATES WITH MODULAR PLUG CONFORMING TO FCC PART 68, SUBPART F.

PART NUMBER: 59A-S1108A-E2XX

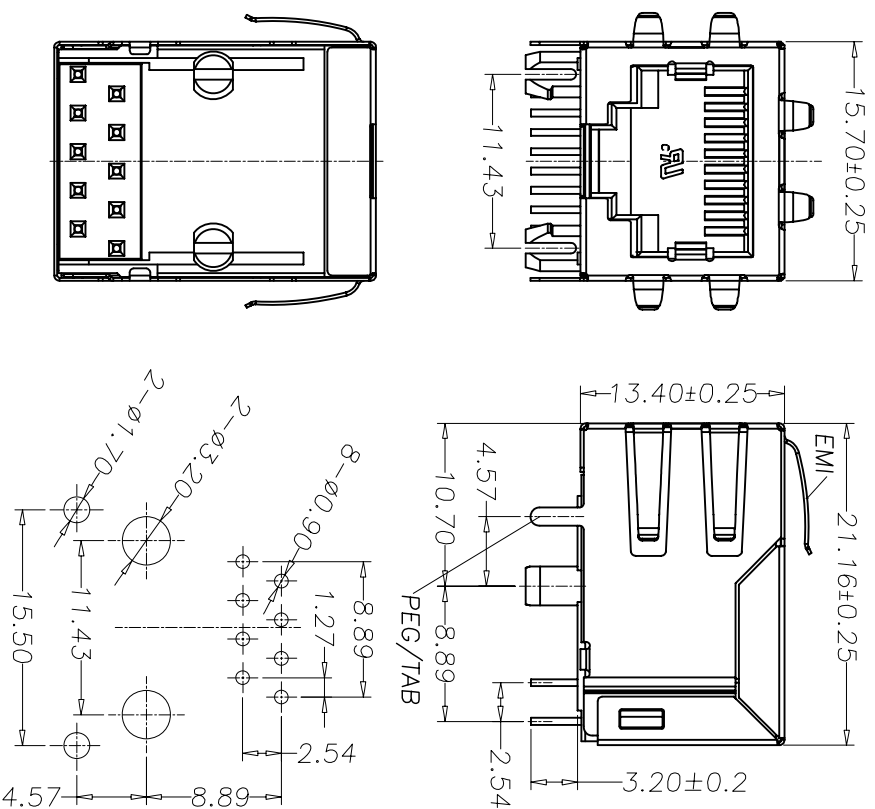

PC Board Layout



HTTP://WWW.RJ45JACK.COM		YOU LONG CONNECT THE WORLD	
:Inspection Item		YOU LONG ELECTRONICS LIMITED	
:Cp/Cpk and SPC Control Item		图号 DWG NO. YL59A-S1108A-E2	
DIMENSION IN mm [Inch]		图号 FILE NO.	
TOLERANCE UNLESS OTHERWISE SPECIFIED		图号 DWG NO. YL59A-S1108A-E2	
.X±0.20	X*±1*	图号 FILE NO.	
.XX±0.15	.X*±0.5*	图号 FILE NO.	
.XXX±0.075		图号 FILE NO.	
批准 APPROVE	检查 CHECK	图号 FILE NO.	
Oscar		图号 FILE NO.	
SCALE 1:1		图号 FILE NO.	
A3		图号 FILE NO.	
REV 1		图号 FILE NO.	
A		图号 FILE NO.	

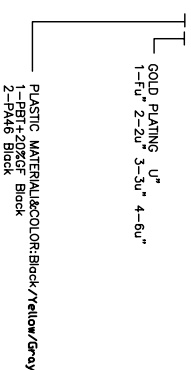

If you have any questions, Don't hesitate to email sales@rj45jack.com, please!