

1 2 3 4 5 6 7 8

| | | | | |
|-----------|----------------------|------------|------------|---------------|
| 更改 REV | 变更内容 MODIFICATION | 日期 DATE | 制图 DRAW | 审核 APPROVE |
| A | 版面发行 | 2012/10/29 | JDL | Oscar |
| | | | | |

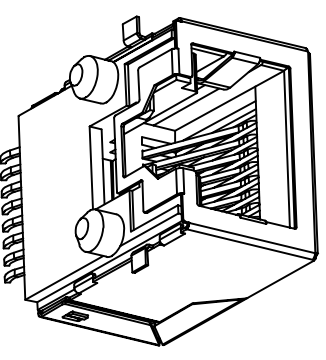
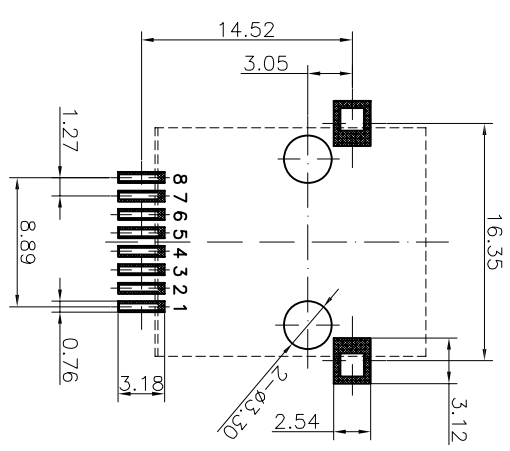
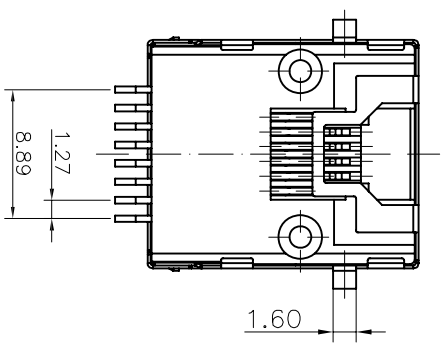
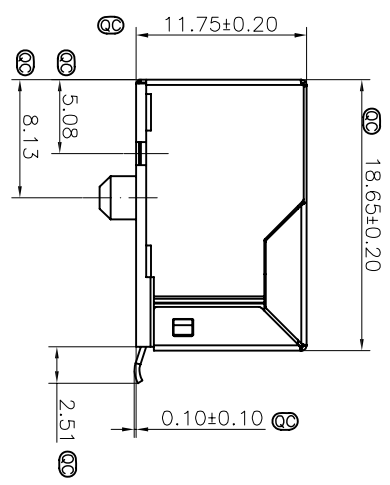
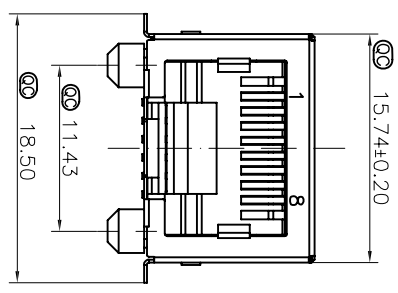

PCB LAYOUT/TOP VIEW

- NOTES:
- ELECTRICAL:**
- VOLTAGE RATING : 125 VAC RMS.
 - CURRENT RATING : 1.5 AMP.
 - CONTACT RESISTANCE : 50 MILLIOHMS MAX.
 - INSULATION RESISTANCE: 500 MEGOHMS MIN @ 500 VDC.
 - DIELECTRIC STRENGTH : 500 VAC RMS 50Hz, 1MIN.

- MECHANICAL:**
- HOUSING MATERIAL : NYLON(PA46)+30%G.F UL94V-0.
 - CONTACT MATERIAL : PHOSPHOR BRONZE T=0.35mm (C5210) GOLD-PLATED IN THE CONTACT AREA
 - PLATING : GOLD-PLATED IN THE CONTACT AREA
 - SHIELD COPPER ALLOY(OR STEEL ALLOY) 0.20mm THICKNESS
 - OPERATING LIFE : 750 CYCLES MIN.
 - PCB RETENTION PRE-SOLDER : 1 LB MIN.
 - PCB RETENTION POST-SOLDER: 10 LBS MIN.
- ENVIRONMENTAL:**
- STORAGE : -40°C TO +85°C.
 - OPERATION: 0°C TO +70°C.
 - IR REFLOW PEAK SOLDERING TEMPERATURE:255°C~265°C 5~10 SECONDS.
 - ROHS COMPLIANT
- FCC PART 68, SUBPART F.
MATES WITH MODULAR PLUG CONFORMING TO

PART NUMBER: SMTB-S1188D-H2X

GOLD PLATING "u"
1-3u" 2-6u" 3-15u" 4-30u"

| | | | |
|--------------------------------------|----------|---|--|
| HTTP://WWW.RJ45JACK.COM | | YOU LONG CONNECT THE WORLD | |
| :Cp/Cpk and SPC Control Item | | YOU LONG ELECTRONICS LIMITED | |
| :Inspection Item | | TITLE SMT 1X1 8P8C PCB JACK WITH SHIELDED | |
| DIMENSION IN mm [Inch] | | FILE NO. | |
| TOLERANCE UNLESS OTHERWISE SPECIFIED | | 图号 | |
| .X±0.20 | X*±1" | DWG NO. YLSMTB-S1188D-H2 | |
| .XX±0.15 | .X*±0.5" | | |
| .XXX±0.075 | | 规格 | |
| 批准 | 检查 | Oscar | |
| 批准 | 检查 | 1:1 | |
| 批准 | 检查 | A3 | |
| 批准 | 检查 | 1 | |
| 批准 | 检查 | A | |

1 2 3 4 5 6 7 8

If you have any questions,Don't hesitate to email sales@rj45jack.com,please!